

eLite Solar Charger Manual

Suitable for eLite Electric Outboard Motor

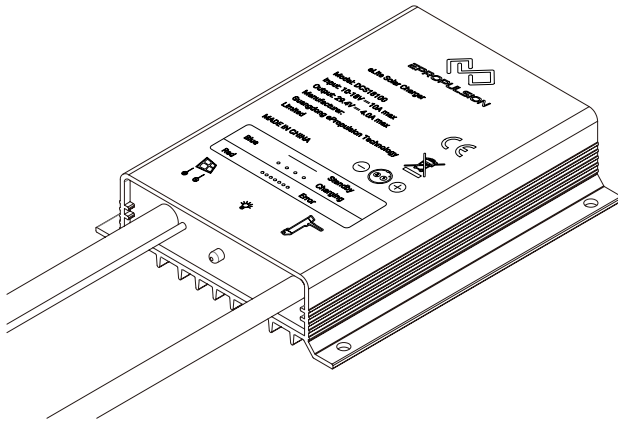

Motor: DCS18100

Please read this manual carefully before use.

Introduction

Thank you for purchasing ePropulsion Solar Charge Controller. This solar charge controller is specially designed for eLite Electric Outboard Motor. Fast Maximum Power Point Tracking (MPPT) technology (efficiency $\geq 99.9\%$) precisely positions the maximum power point of PV cells thus drawing more Photovoltaic energy. With improved system efficiency, the charging conversion efficiency reaches as high as 90%. The controller is not only designed to work perfectly with a wide variety of solar panels with input voltage $\leq 18V$. but also can get power from other sources with input voltage of 12V DC.

Declaration of Conformity

We Guangdong ePropulsion Technology Limited, hereby, declares that this equipment is compliance with the applicable Directives and European Norms, and amendments.

Object of the Declaration:

Product: eLite Solar Charger

Model: DCS18100



The object of the declaration is in conformity with the following directives:

Electromagnetic Compatibility (EMC)

2014/30/EU

RoHS 2.0 Directive(RoHS)

2011/65/EU and (EU)2015/863

Applied Standards:

EN IEC 61000-6-3:2021

EN IEC 61000-6-1:2019

EN 62321-2:2014

EN 62321-3-1:2014

EN 62321-4:2014+A1:2017

EN 62321-5:2014

EN 62321-6:2015

EN 62321-7-1:2015

EN 62321-7-2:2017

EN 62321-8:2017

EC REP

Name: REP Europe GmbH

Address: Werner-von-Siemens-Str. 264319 Pfungstadt Germany

Phone: +49 157 51253212

info@rep-europe.de

Manufacturer

Name: Guangdong ePropulsion Technology Limited

Address: Room 801, Building 1, 11 Daxue Road, Songshan Lake, Dongguan, Guangdong Province, China

Signature:  Date: 2nd of Jan, 2023

Shizheng Tao, Chief Executive Officer & Cofounder of Guangdong ePropulsion Technology Limited

Statement

Operation is subject to the following three conditions:

- (1) This device may not cause harmful interference, and
- (2) this device must accept any interference received, including interference that may cause undesired operation.

Note:

This equipment has been tested and found to comply with the limits for a Class B digital device, pursuant to part 15 of the FCC Rules. These limits are designed to provide reasonable protection against harmful interference in a residential installation. This equipment generates, uses and can radiate radio frequency energy and, if not installed and used in accordance with the instructions, may cause harmful interference to radio communications. However, there is no guarantee that interference will not occur in a particular installation. If this equipment does cause harmful interference to radio or television reception, which can be determined by turning the equipment off and on, the user is encouraged to try to correct the interference by one or more of the following measures:

- Reorient or relocate the receiving antenna.
- Increase the separation between the equipment and receiver.
- Connect the equipment into an outlet on a circuit different from that to which the receiver is connected.
- Consult the dealer or an experienced radio/TV technician for help.

Disposal and environment



This marking indicates that this product should not be disposed with other household wastes throughout the EU. To prevent possible harm to the environment or human health

from uncontrolled waste disposal, recycle it responsibly to promote the sustainable reuse of material resources. To return your used device, please use the return and collection systems or contact the retailer where the product was purchased. They can take this product for environmental safe recycling.

Specifications

Battery	
Rated system voltage	25.2V
Charging Voltage Range	19 - 30V
MPPT Charging Voltage @ 25 C	≤25.2V
CV Charging Voltage @25 C	25.2V
Maximum CC Charging Current	4A
PV	
Power	100W
Maximum Input Charging Current	10A
Open Voltage	<23V
MPPT Tracking Range	12V≤Vp≤18V
System	
MPPT Efficiency	≥99.9%
Power Consumption	< 10mA
Temperature Protection	>70°C
Storage/Operation Temperature	-35~65°C
Storage/Operation Humidity	65%±25%RH
Altitude	3000m
Protection Grade	IP67
Certification	CE-EMC ROHS FCC-SDOC
Power Display	1 Bi-colored LED
Weight	403g
Dimensions	100X82X23.5mm
12V Cable length	Approx. 1.3m

Installation Instructions:

Remove the rubber strip and fix the eLite Solar Charger with screws.

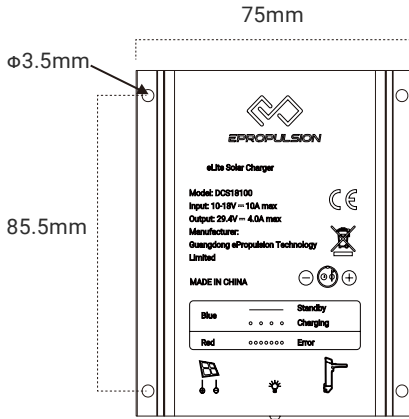

Operations

Step 1: Connecting to eLite Electric Outboard Motor.

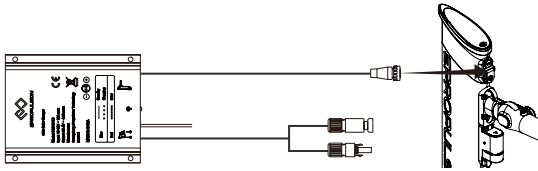

Step 2: Connecting to Power Source

a. Connecting to a Solar Panel

Connect the solar charge controller to the solar panel.

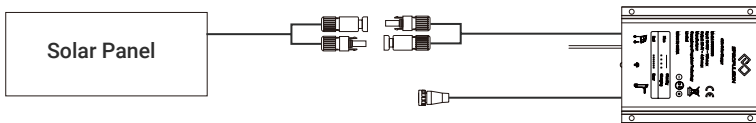

💡 Input voltage of solar panel should be $\leq 23\text{V}$

b. Connecting to 12V Power Source

First Connect the solar charge controller with the 12V Input Cable, then connect the 12V Input Cable to the 12V power source on your boat or car.

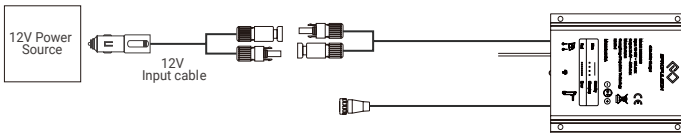

LED Indicator

There is a bio-colored LED indicating mode of the solar charger.

LED Color	LED Status	Mode
Blue	Steady light	Standby
	Flashing Light slowly	Charging
Red	Flashing Light quickly	Error

Notes

- Do not puncture, throw, drop, bend or modify the Solar Charge Controller.
- The controller should be used in well ventilated, dry, particle free environment.
- The controller should avoid direct sun exposure.
- The aluminum case is an important means of heat dissipation, thus should not be covered.
- Opening the housing of the charger without prior written consent of the manufacturer voids the manufacturer's warranty immediately.

Warranty

ePropulsion Solar Charge Controller is guaranteed against any manufacturing defects for TWO years from date of delivery of products to end customers.

Free warranty is only validated upon the presentation of legal serial number, Warranty Card, and evidence of purchase from an authorized ePropulsion dealer.

Conditions:

Valid date of purchase should be established by the first-hand purchaser with original sales slip.

Free warranty is not transferable and will not be reissued.

The warranty is valid only when the information is correct and complete.

Warranty does not cover:

Minor faults producing no influence on the intended function of the product.

Faults resulting from any improper operation that contradicts the user manual.

Accessories supplied with the product.

Damage caused by accident, misuse or unauthorized repair.

Damage caused by dropping, improper care or storage.

If warranty expires, users can still enjoy maintenance services from ePropulsion authorized dealers with minimum maintenance charge.

Packing List

Item	Qty.
Solar Charge Controller	1 Set
12V Input Cable	1 PC
Manual	1 PC
MC4 Connector Spanner	1 PC

ePropulsion

(*In order to validate warranty, please fill in this form first and read the Warranty Policies.)

|| OWNER INFO. ||

Owner Name			
Address			
Phone		Email	

|| DEALER INFO. ||

Store Name			
Address			
Phone		Email	

|| PRODUCT INFO. ||

Date of Purchase (mm/dd/yyyy)	
Serial No.	



Thanks for reading this user manual.

If you have any concerns or find any problems while reading, please don't hesitate to contact us. We are delighted to offer service for you.

Guangdong ePropulsion Technology Limited

Webseite: www.epropulsion.com

E-Mail: service@epropulsion.com